

2018 FORESTER



Subaru Forester. A whole lot to love.

 **SUBARU.**
Confidence in Motion

Do what you love, **and do it often.**

The 2018 Subaru Forester

Inspired to do more. Outstanding versatility, great fuel economy and an impressive safety reputation make the 2018 Forester a favorite when it comes to pursuing your passions with those you care about the most.



Efficient

Its available Lineartronic® CVT gives you optimal MPG at every speed, and combined with its efficient SUBARU BOXER® engine, the Forester earns up to 32 highway MPG.¹



Versatile

Subaru Symmetrical AWD helps you drive with confidence, while the available X-MODE® terrain feature with Hill Descent Control² helps you more easily navigate steep and slippery roads with confidence. There's also 8.7 inches of ground clearance, so you can take on nearly any path.



Safe

Get extra peace of mind for your daily drive with available safety technologies like Blind-Spot Detection,³ Rear Cross-Traffic Alert³ and EyeSight® Driver Assist Technology.⁴ SUBARU STARLINK™ Safety and Security is available as well to help keep you and your Subaru safe and sound.⁵



Spacious

Available reclining rear seats and generous leg room make the cabin especially comfortable for rear passengers, while the available power rear gate gives you easy access to the large cargo area. To maximize its cargo capability, we gave the Forester an extra-wide rear opening as well.

1 EPA-estimated fuel economy for 2018 Forester 2.5i CVT at 32 highway MPG. Actual mileage may vary. 2 Requires Lineartronic® CVT. Not available on 2.5i base models. See your retailer for details. 3 Blind-Spot Detection, Lane Change Assist and Rear Cross-Traffic Alert are systems designed to assist the driver by monitoring the rear and side areas of the vehicle during a lane change or reversing and are not a substitute for safe and attentive driving. 4 EyeSight is a driver assist technology, which may not operate optimally under all driving conditions. The driver is always responsible for safe and attentive driving. System effectiveness depends on many factors such as vehicle maintenance, weather and road conditions. See Owner's Manual for complete details on system operations and limitations. 5 Activation with subscription is required. See your retailer for details.



Forester 2.5i Touring with Saddle Brown Leather.



SUBARU STARLINK™ Safety and Security



STARLINK™ Multimedia Navigation

Well-equipped Interior

There's a lot to enjoy in the 2018 Forester like rich materials and a large panoramic moonroof to give the cabin a wide-open feeling. There's also a 4.3-inch, full-color multifunction display for accessing info like vehicle settings, average fuel economy and the available EyeSight® Driver Assist Technology.¹

Plus, standard SUBARU STARLINK™ Multimedia gives you access to music, news, navigation and other content through Pandora,® Aha,™ available STARLINK™ apps and more on either a 6.2- or 7.0-inch high-resolution touchscreen. It displays the view from the standard Rear-Vision Camera when you're backing up, too. STARLINK™ Safety and Security² is also available to help keep you and your Subaru safe with services like Automatic Collision Notification that can send the appropriate first responder if an airbag deploys.

¹ EyeSight is a driver assist technology, which may not operate optimally under all driving conditions. The driver is always responsible for safe and attentive driving. System effectiveness depends on many factors such as vehicle maintenance, weather and road conditions. See Owner's Manual for complete details on system operations and limitations. ² Activation with subscription is required. See your retailer for details.



Lots of room for lots of possibilities.

Forester 2.5i Limited with Platinum Gray Leather.

© 2018 Forester

An extra set of eyes **every time you drive.**

Pre-Collision Braking



A driver ahead unexpectedly hits the brakes or cuts you off. EyeSight^{®1} warns you, applies brakes to help avoid impact and, at lower speeds, can even help you stop your Subaru.

Adaptive Cruise Control

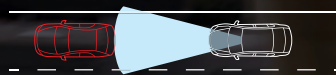

Traffic doesn't always flow smoothly, so EyeSight[®] doesn't only keep a set speed. The system looks ahead and helps automatically adjust to keep your distance, even in stop-and-go highway traffic.

Pre-Collision Throttle Management



If you put the car in Drive instead of Reverse and EyeSight[®] sees an object in your path, it cuts power to help you avoid accelerating into it.

Lane Departure and Sway Warning with Lane Keep Assist

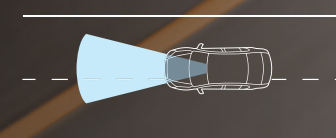

You accidentally drift to the edge of your lane and begin to cross into another. EyeSight[®] watches for lane markers and chimes to warn you before you leave your lane, and it can even help steer you back into your proper course, thanks to Lane Keep Assist.

The Subaru Forester received the **highest possible 2017 rating for front crash prevention** when equipped with EyeSight.

– Insurance Institute for Highway Safety (IIHS)



¹ EyeSight is a driver assist technology, which may not operate optimally under all driving conditions. The driver is always responsible for safe and attentive driving. System effectiveness depends on many factors such as vehicle maintenance, weather and road conditions. See Owner's Manual for complete details on system operations and limitations.

Safe and sound is what we do best.

Enhanced Safety Features

Well-built means well-protected in the 2018 Forester. You can count on standard features like a Rear-Vision Camera and seven airbags.¹ Plus, its standard AWD capability means you'll have control, even in unfavorable weather. There are also available features like Reverse Automatic Braking², as well as LED Steering Responsive Headlights to help you see around corners more easily and available High Beam Assist to automatically initiate and dim the high beams as needed.

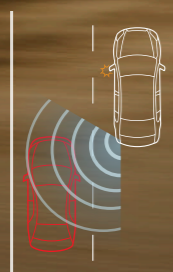

Blind-Spot Detection

Using radar sensors, Blind-Spot Detection warns you with a visual indicator in your side mirror if it senses a vehicle in your blind spot. Another feature of this system, **Lane Change Assist**, alerts you with a flashing indicator in your side mirror if it senses a vehicle approaching at a higher speed in a neighboring lane and you signal for a lane change.³

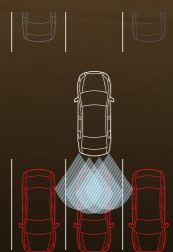

Reverse Automatic Braking

Reverse Automatic Braking² can detect objects directly behind your vehicle when backing up at a low speed and can help bring the Forester to a stop should an object be detected within its range and the driver fail to act. There's also a Rear-Vision Camera to help you keep an eye out.

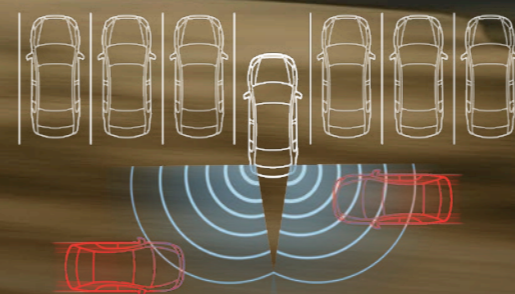

Rear Cross-Traffic Alert

Rear Cross-Traffic Alert uses radar sensors to help warn you of traffic approaching from the side as you are backing up, utilizing a flashing visual indicator in your side mirror and an audible warning.³

SUBARU
STARLINK
YOUR SUBARU CONNECTED

SUBARU STARLINK™ Safety and Security

Instant access to help when you need it most 24/7, 365 days a year. That's the reassurance of STARLINK™ Safety and Security, which can send first responders when an airbag deploys, help police locate your vehicle if it's stolen, notify you if your vehicle's security alarm is activated, and more.⁴

¹ Always wear seatbelts. Children should be properly restrained in the rear seat. ² This system is not a substitute for safe and attentive driving. System effectiveness depends on many factors, such as vehicle maintenance, weather and road conditions. Always exercise caution and use vehicle mirrors and the Rear-Vision Camera when backing up. See Owner's Manual for complete details on system operation and limitations. ³ Blind-Spot Detection, Lane Change Assist and Rear Cross-Traffic Alert are systems designed to assist the driver by monitoring the rear and side areas of the vehicle during a lane change or reversing and are not a substitute for safe and attentive driving. ⁴ Activation with subscription is required. See your retailer for details.

A turbocharged **taskmaster.**

Forester 2.0XT

Utility with just the right amount of sport, the Forester 2.0XT features a Direct Injection Turbocharged (DIT) SUBARU BOXER® engine with 250 hp and 258 lb-ft of torque on tap to amp up its performance potential. This advanced engine is mated with a high-torque Lineartronic® CVT featuring paddle shifters with 6- and 8-speed manual modes¹ to help you achieve up to 27 highway MPG,² while keeping things fun behind the wheel.

Pumping out the extra rush the way you want it is Subaru Intelligent Drive (SI-DRIVE) with three distinctive performance modes for customized response at the push of a button. On the outside, its aggressive looks and large 18-inch wheels reveal the fiercer side of the Forester 2.0XT.

¹ 8-speed manual mode with SI-DRIVE Sport Sharp (S#) setting.
² EPA-estimated fuel economy for 2018 Forester 2.0XT at 27 highway MPG. Actual mileage may vary.



Direct Injection Turbocharged (DIT) SUBARU BOXER® Engine



Manual-mode Paddle Shifters and SI-DRIVE



The **best-selling all-wheel drive cars** in America for the past 10 years.¹

IHS Markit



“The Subaru Forester is one of an increasingly rare breed that is **equally adept on-road and off-road.**”

Kelley Blue Book's KBB.com

2018 Forester | Trim Levels



2.5i

- 170-hp 2.5-liter 4-cylinder SUBARU BOXER® engine
- Subaru Symmetrical All-Wheel Drive
- 6-speed manual transmission or optional Lineartronic® CVT (Continuously Variable Transmission)
- 17-inch styled steel wheels
- Cloth upholstery
- 6-way manually adjustable driver's seat. 4-way manually adjustable front-passenger's seat.
- SUBARU STARLINK™ 6.2-inch Multimedia with smartphone app integration,⁵ Bluetooth® audio streaming and hands-free phone connectivity
- Manually adjustable CFC-free air conditioning system with air filtration
- Driver's auto-up/down power window
- Analog gauges with LCD display
- Color multifunction display
- Rear-Vision Camera



2.5i Premium

Includes 2.5i key features and adds:

- 17-inch aluminum-alloy wheels
- Panoramic moonroof
- Raised roof rails: black finish
- Rear spoiler
- Body-color side mirrors
- 10-way power adjustable driver's seat
- Reclining rear seatbacks
- SUBARU STARLINK™ 7.0-inch Multimedia Plus with smartphone app integration,⁵ Siri® Eyes Free, SiriusXM® All Access Radio⁶ and Travel Link^{6b}
- SUBARU STARLINK™ Safety Plus enabled⁷
- Dual USB ports
- Automatic climate control system
- Front-passenger's auto-up/down power window
- All-Weather Package⁸
- Privacy glass



Subaru is Kelley Blue Book's **2017 Most Trusted Brand, Best Overall Brand, and lowest 5-Year Cost to Own.²**



2.5i Touring

Includes 2.5i Limited key features and adds:

- 18-inch aluminum-alloy wheels
- LED Steering Responsive Headlights (SRH) with High Beam Assist (HBA)
- Body-color side mirrors with integrated turn signals
- Chrome accents on lower door cladding
- Keyless Access with Push-Button Start and PIN-code vehicle access
- SUBARU STARLINK™ Multimedia Navigation with SiriusXM Traffic^{9,10}
- 440-watt-equivalent Harman Kardon® audio system with 8 speakers
- EyeSight® Driver Assist Technology¹¹
- Reverse Automatic Braking (RAB)¹²
- Heated steering wheel
- 2-position driver's seat memory
- Dual-zone automatic climate control system
- One-touch folding rear seatback
- Shifter handle with leather boot and gloss black trim



2.0XT Premium

Includes 2.5i Premium key features and adds:

- 250-hp turbocharged 2.0-liter 4-cylinder SUBARU BOXER® engine
- Subaru Symmetrical All-Wheel Drive with X-MODE® featuring Hill Descent Control (HDC)
- Lineartronic® CVT (Continuously Variable Transmission) with manual-mode paddle shifters
- Sport-tuned suspension
- SI-DRIVE
- 18-inch aluminum-alloy wheels
- Auto-on/off headlights
- Sport cloth upholstery
- Leather-wrapped steering wheel and shifter handle
- Shifter handle with leather boot and gloss black trim
- Welcome lighting

Bolder in Black

The 2018 Forester 2.5i Premium Black Edition kicks up your everyday with sharp 18-inch gloss black wheels, gloss black mirror caps and badging, as well as standard Blind-Spot Detection with Lane Change Assist and Rear Cross-Traffic Alert^{9,13} EyeSight® Driver Assist Technology^{11,13} and LED Steering Responsive Headlights (SRH) to help you see around corners. Inside, you'll find standout touches like a leather-wrapped steering wheel with paddle shifters, silver and gloss black dash trim, and exclusive Black Cloth seats with Sport Bolsters, to name a few. It's available in Crystal Black Silica, Crystal White Pearl, Ice Silver Metallic and Dark Gray Metallic.

2.5i Premium Black Edition

Includes 2.5i Premium key features and adds:

- Subaru Symmetrical All-Wheel Drive with X-MODE® featuring Hill Descent Control (HDC)
- Lineartronic® CVT (Continuously Variable Transmission) with manual-mode paddle shifters
- 18-inch gloss black aluminum-alloy wheels
- LED Steering Responsive Headlights (SRH)
- Fog lights
- Crystal Black Silica badging and mirror caps
- Exclusive Black Cloth seats with Sport Bolsters
- EyeSight® Driver Assist Technology^{11,13}
- Blind-Spot Detection with Lane Change Assist and Rear Cross-Traffic Alert^{9,13}
- Leather-wrapped steering wheel
- Shifter handle with leather boot and gloss black trim
- Silver metallic and gloss black interior accent trim
- Analog gauges with color LCD display and electroluminescent lighting¹³
- Cargo area tray

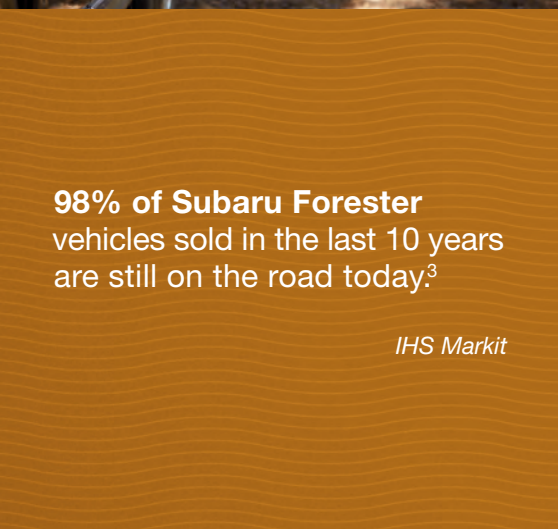

98% of Subaru Forester vehicles sold in the last 10 years are still on the road today.³

IHS Markit



The Subaru Forester retains **its value better than any other vehicle in its class for 2017, according to ALG.⁴**



1 Based on IHS Markit total registrations among all-wheel drive vehicles from 2007–2016. 2 2017 Kelley Blue Book Brand Image Awards are based on the Brand Watch™ study from Kelley Blue Book Strategic Insights. Award calculated among non-luxury shoppers. 2017 model-year vehicle's projected cost to own for the initial five-year ownership period is based on the average Kelley Blue Book 5-Year Cost to Own data which considers depreciation and costs such as fuel and insurance. For more information, visit www.kbb.com. Kelley Blue Book is a registered trademark of Kelley Blue Book Co., Inc. 3 Based on IHS Markit U.S. vehicles in operation vs. total new registrations in the Non-Luxury Compact CUV segment for MY2007–2016 as of January 2017. 4 ALG is the industry benchmark for residual values and depreciation data, www.alg.com. 5 Compatible smartphone and applications required. For applications to operate, latest version of each application is required. Data provided by smartphone is displayed on the audio system screen. Some state laws prohibit the operation of handheld electronic devices while operating a vehicle. Smartphone apps should only be launched when vehicle is safely parked. Your wireless carrier's rates may apply. 6 Activation and required monthly subscription sold separately. Includes 4-month trial subscription. See your retailer. 7 Activation and required subscription sold separately. Includes 1-year trial subscription. See retailer for details. 8 Standard with manual transmission. Optional with Lineartronic® CVT. 9 Blind-Spot Detection, Lane Change Assist and Rear Cross-Traffic Alert are systems designed to assist the driver by monitoring the rear and side areas of the vehicle during a lane change or reversing and are not a substitute for safe and attentive driving. 10 Activation and required monthly subscription sold separately. Includes 3-year trial subscription. See your retailer. 11 EyeSight is a driver assist technology, which may not operate optimally under all driving conditions. The driver is always responsible for safe and attentive driving. System effectiveness depends on many factors such as vehicle maintenance, weather and road conditions. See Owner's Manual for complete details on system operations and limitations. 12 This system is not a substitute for safe and attentive driving. System effectiveness depends on many factors, such as vehicle maintenance, weather and road conditions. Always exercise caution and use vehicle mirrors and the Rear-Vision Camera when backing up. See Owner's Manual for complete details on system operation and limitations. 13 Late availability. See your retailer for details.

2018 Forester | Specifications



2.5i Limited

Includes 2.5i Premium key features and adds:

- Subaru Symmetrical All-Wheel Drive with X-MODE® featuring Hill Descent Control (HDC)
- Lineartronic® CVT (Continuously Variable Transmission)
- Fog lights
- Power rear gate with automatic close and height memory
- Auto-on/off headlights
- Leather-trimmed upholstery
- Leather-wrapped steering wheel and shifter handle
- Silver metallic and gloss black interior accent trim
- Blind-Spot Detection with Lane Change Assist and Rear Cross-Traffic Alert®
- Analog gauges with color LCD display and electroluminescent lighting
- Removable cargo-area tray and cover
- Welcome lighting



2.0XT Touring

Includes 2.5i Touring key features and adds:

- 250-hp turbocharged 2.0-liter 4-cylinder SUBARU BOXER® engine
- Lineartronic® CVT (Continuously Variable Transmission) with manual-mode paddle shifters
- Active Torque Vectoring
- Sport-tuned suspension
- SI-DRIVE

Engine and Drivetrain		2.5i	2.0XT
Engine Power Torque	2.5-liter DOHC aluminum-alloy 16-valve 4-cylinder horizontally opposed SUBARU BOXER® engine with Active Valve Control System (AVCS). 170 hp @ 5,800 rpm 174 lb-ft @ 4,100 rpm	●	—
	2.0-liter DOHC Direct Injection Turbocharged (DIT), intercooled aluminum-alloy 16-valve 4-cylinder horizontally opposed SUBARU BOXER® engine with Dual Active Valve Control System (DAVCS). 250 hp @ 5,600 rpm 258 lb-ft @ 2,000-4,800 rpm	—	●
SI-DRIVE performance management system	Subaru Intelligent Drive (SI-DRIVE) enables three distinctively different modes of vehicle performance characteristics by regulating the engine control unit (ECU) and the transmission control unit (TCU) as well as fine-tuning the electronically controlled throttle.	—	●
Manual Transmission	Fully synchronized 6-speed manual with Incline Start Assist. 2.5i and 2.5i Premium: Standard. 2.5i Limited, 2.5i Touring, 2.0XT Premium and 2.0XT Touring: Not available.	●	—
Automatic Transmission	Lineartronic® CVT (Continuously Variable Transmission) with Adaptive Control, Incline Start Assist and 6- and 8-speed manual modes (2.0XT models). 2.5i and 2.5i Premium: Optional. 2.5i Limited, 2.5i Touring, 2.0XT Premium and 2.0XT Touring: Standard.	○	●
CA Emissions		LEV III/SULEV 30	LEV2
Maximum towing capacity	1,500 lbs	●	●
Traction and Stability			
All-Wheel Drive type	Subaru Symmetrical All-Wheel Drive	●	●
X-MODE®	X-MODE® optimizes engine output and transmission ratio, increases all-wheel drive system engagement and uses enhanced control of the VDC system to reduce individual wheelspin, providing optimal traction on low-friction surfaces. 2.5i: Not available. 2.5i Premium: Optional! 2.5i Limited, 2.5i Touring, 2.0XT Premium and 2.0XT Touring: Standard.	○	●
Hill Descent Control (HDC)	X-MODE® also incorporates Hill Descent Control (HDC) that helps to maintain a constant vehicle speed when traveling downhill, enhancing vehicle control. 2.5i: Not available. 2.5i Premium: Optional! 2.5i Limited, 2.5i Touring, 2.0XT Premium and 2.0XT Touring: Standard.	○	●
Vehicle Dynamics Control (VDC)	VDC electronic stability control utilizes sensors that constantly monitor wheel speeds, steering angle, brake pressure, vehicle yaw rate and lateral g-forces. If VDC detects a difference between the driver's intended path and the one the vehicle is actually taking, VDC applies braking power and/or reduces engine torque to help correct vehicle path.	●	●
Active Torque Vectoring	Active Torque Vectoring works in tandem with VDC, applying braking power to the inside front wheel, resulting in sharper turn-in, more neutral steering and higher cornering limit while turning.	—	○²
Traction Control System (TCS)	VDC also incorporates an all-wheel, all-speed traction control system that senses a loss of traction and applies braking force to the slipping wheel or wheels as necessary to maintain vehicle motion.	●	●

● Standard ○ Optional — Not equipped

2018 Forester | Specifications

Fuel		2.5i	2.0XT
Fuel Economy	city/highway/combined³	Manual: 22/28/24 mpg Automatic: 26/32/28 mpg	23/27/25 mpg
Fuel Requirement		Unleaded gasoline (87 octane)	Premium unleaded gasoline recommended (91 octane. 93 octane for maximum performance.)
Fuel Capacity	15.9 gallons	●	●
Chassis			
Steering	Electric power-assisted rack-and-pinion steering (EPAS). Turning circle: 34.8 feet	●	●
Suspension	4-wheel independent. Front: Strut-type with lower L-arm. Stabilizer bar. Rear: Double wishbone. Stabilizer bar. 2.0XT models: Sport-tuned.	●	●
Brakes	4-wheel disc. 4-channel, 4-sensor ABS with Electronic Brake-force Distribution (EBD). 2.5i: Ventilated front. 2.0XT: Ventilated front and rear.	●	●
Brake Discs (front/rear)	2.5i, 2.5i Premium, 2.5i Limited and 2.5i Touring: 11.6 inches/10.8 inches. 2.0XT Premium and 2.0XT Touring: 12.4 inches/10.9 inches.	●	●
Brake Assist	When emergency braking is detected by how quickly the brake pedal is pressed, maximum brake pressure is immediately applied.	●	●
Brake Override System	If both brake and accelerator pedals are pressed simultaneously, the system reduces the operation of the accelerator pedal to help prevent unintentional vehicle acceleration.	●	●
Wheels and Tires			
Wheels	2.5i: 17 x 7.0-inch steel. 2.5i Premium, 2.5i Limited and Alloy Wheel Package: 17 x 7.0-inch 6-spoke aluminum-alloy. Black with machine finish. 2.5i Touring: 18 x 7.0-inch 5-spoke aluminum-alloy. High-luster silver finish. 2.0XT Premium and 2.0XT Touring: 18 x 7.0-inch split 5-spoke aluminum-alloy. Black with machine finish.	●	—
Tires	2.5i, 2.5i Premium, 2.5i Limited and Alloy Wheel Package: 225/60 R17 98H All-season 2.5i Touring, 2.0XT Premium and 2.0XT Touring: 225/55 R18 97H All-season	●	—
Spare Tire	Temporary use T145/80 D17	●	●

2018 Forester | Equipment

Exterior	2.5i	2.5i Premium	2.5i Limited	2.5i Touring	2.0XT Premium	2.0XT Touring
LED Steering Responsive Headlights (SRH)	—	—	○ ⁴	●	—	●
Fog lights	□	○ ⁴	●	●	□	●
Rear spoiler	—	●	●	●	●	●
Black side mirrors	●	—	—	—	—	—
Body-color side mirrors	—	●	●	—	●	—
Body-color side mirrors with integrated turn signals	—	—	—	●	—	●
Chrome accents on lower door cladding	—	—	—	●	—	●
Panoramic moonroof (99% UV light reducing) ⁵	—	●	●	●	●	●
Windshield wiper de-icer and heated side mirrors (All-Weather Package)	—	○ ⁶	●	●	●	●
Raised roof rails: black finish	○ ⁴	●	●	●	●	●
Seating and Trim						
6-way manually adjustable driver's seat. 4-way manually adjustable front-passenger's seat.	●	—	—	—	—	—
10-way power adjustable driver's seat with power adjustable lumbar support. 4-way manually adjustable front-passenger's seat.	—	●	●	●	●	●
2-position driver's seat memory	—	—	—	●	—	●
Heated steering wheel	—	—	—	●	—	●
Heated front seats (All-Weather Package)	—	○ ⁶	●	●	●	●
Reclining rear seatback	—	●	●	●	●	●
60/40-split flat-folding rear seatback	●	●	●	●	●	●
One-touch folding rear seatback	—	—	—	●	—	●
Leather-wrapped steering wheel and shifter handle	—	—	●	●	●	●
Shifter handle with leather boot and gloss black trim	—	—	—	●	●	●
Cloth upholstery	●	●	—	—	●	—
Leather-trimmed upholstery	—	—	●	●	—	●
Convenience						
Keyless Access with Push-Button Start and PIN-code vehicle access	—	—	—	●	—	●
One-touch lane change feature	●	●	●	●	●	●
Auto-on/off headlights	—	—	●	●	●	●
Power rear gate with automatic close and height memory functions	—	○ ⁴	●	●	—	●
Driver's auto-up/down power window	●	—	—	—	—	—
Driver's and front-passenger's auto-up/down power windows	○ ⁴	●	●	●	●	●
3-spoke steering wheel with audio system, Bluetooth® SI-DRIVE (2.0XT only), and cruise control (or if equipped, EyeSight® System Adaptive Cruise Control) buttons	●	●	●	●	●	●
Lineartronic® CVT manual-mode paddle shifters	—	—	—	—	●	●
Manually adjustable tilt/telescoping steering column	●	●	●	●	●	●
Cup holders	6	8	8	8	8	8
Rear center armrest	—	●	●	●	●	●
Cargo-area with 2 grocery bag hooks, 4 tie-down hooks and underfloor storage	●	●	●	●	●	●
Removable cargo-area tray and cover	□	□	●	●	□	●
Welcome lighting	—	—	●	●	●	●
Audio and Navigation Systems						
SUBARU STARLINK™ 6.2-inch Multimedia with Pandora®, iHeartRadio®, Stitcher™ and Aha™ smartphone app integration ⁷ , high-resolution LCD touchscreen display, 4 speakers, AM/FM/CD player, HD Radio® with iTunes® tagging capability, USB port/iPod® control, Bluetooth® audio streaming and hands-free phone connectivity, and 3.5-mm auxiliary jack	●	—	—	—	—	—
SUBARU STARLINK™ 7.0-inch Multimedia Plus with Pandora®, iHeartRadio®, Stitcher™ and Aha™ smartphone app integration ⁷ , high-resolution LCD touchscreen display, voice-activated controls, Siri® Eyes Free, AM/FM/CD player, HD Radio® with iTunes® tagging capability, USB port/iPod® control, SiriusXM® All Access Radio ⁹ and Travel Link ^{9a} , Bluetooth® audio streaming and hands-free phone and text messaging connectivity, and 3.5-mm auxiliary jack	—	●	●	—	●	—
SUBARU STARLINK™ 7.0-inch Multimedia Navigation: 7.0-inch multi-touch gesture high-resolution GPS navigation system with SiriusXM® All Access Radio ⁹ , Traffic ^{9a} and Travel Link ^{9a} , HD Radio® with iTunes® tagging capability, Siri® Eyes Free, USB port/iPod® control, Bluetooth® audio streaming and hands-free phone and text messaging connectivity, 3.5-mm auxiliary jack and Pandora®, iHeartRadio®, Stitcher™ and Aha™ smartphone app integration ⁷	—	—	○ ⁴	●	—	●
6 speakers	—	●	●	—	●	—
Harman Kardon® audio system with 8 speakers and 440-watt-equivalent amplifier	—	—	○ ⁴	●	—	●

2018 Forester | Equipment

Climate Control	2.5i	2.5i Premium	2.5i Limited	2.5i Touring	2.0XT Premium	2.0XT Touring
Manually adjustable climate control system with air filtration	●	—	—	—	—	—
Automatic climate control system with air filtration	—	●	●	—	●	—
Dual-zone automatic climate control system with air filtration	—	—	—	●	—	●
Instrumentation						
Analog gauges with LCD display	●	●	—	—	●	—
Analog gauges with color LCD display	—	○ ⁴	●	●	—	●
Color multifunction display for driving range, average fuel economy, clock, ambient temperature, climate control and other vehicle functions	●	●	●	●	●	●
Security						
Keyless entry system with answer-back electronic chirp	●	●	●	●	●	●
Antitheft security system with engine immobilizer	●	●	●	●	●	●
Safety						
ACTIVE						
Subaru Symmetrical All-Wheel Drive (AWD)	●	●	●	●	●	●
EyeSight® Driver Assist Technology ^{4,10}	—	○	○	●	—	●
Blind-Spot Detection with Lane Change Assist and Rear Cross-Traffic Alert ¹¹	—	○ ⁴	●	●	—	●
Reverse Automatic Braking (RAB) System ¹²	—	—	○ ⁴	●	—	●
Vehicle Dynamics Control (VDC) with Traction Control System (TCS)	●	●	●	●	●	●
4-wheel antilock braking system (ABS) with Electronic Brake-force Distribution (EBD)	●	●	●	●	●	●
Brake Assist	●	●	●	●	●	●
Brake Override System	●	●	●	●	●	●
Daytime Running Lights (DRL)	●	●	●	●	●	●
Rear-Vision Camera	●	●	●	●	●	●
PASSIVE						
STARLINK™ Safety Plus enabled ¹³ : Automatic Collision Notification, SOS Emergency Assistance, Enhanced Roadside Assistance, Maintenance Notifications, Monthly Vehicle Health Report, Diagnostic Alerts	—	●	●	●	●	●
Subaru advanced frontal airbag system with driver's and front-passenger's airbags (SRS) ¹⁴	●	●	●	●	●	●
Seat-mounted front side-impact airbags (SRS) ¹⁴	●	●	●	●	●	●
Side-curtain airbags protecting front and rear outboard occupants (SRS) ¹⁴	●	●	●	●	●	●
Rollover sensor (SRS) ¹⁴	●	●	●	●	●	●
Driver's knee airbag (SRS) ¹⁴	●	●	●	●	●	●
Height- and tilt-adjustable front-seat head restraints	●	●	●	●	●	●
Height-adjustable 3-point front seatbelts with pretensioners and load limiters. 3-point seatbelts at all rear seating positions.	●	●	●	●	●	●
Rear child-safety door locks	●	●	●	●	●	●
LATCH system: Lower Anchors and Tethers for Children	●	●	●	●	●	●
Optional Equipment						
STARLINK™ Safety Plus and Security Plus ¹⁵	—	○	○	○	○	○
Lineartronic® CVT (Continuously Variable Transmission)	○	○	●	●	●	●
Alloy Wheel Package • Lineartronic® CVT	○	—	—	—	—	—
All-Weather Package • Lineartronic® CVT • X-MODE® with Hill Descent Control	—	○	●	●	●	●
All-Weather Package • Lineartronic® CVT • EyeSight® Driver Assist Technology ¹⁰ • Blind-Spot Detection with Lane Change Assist and Rear Cross-Traffic Alert ¹¹	—	○	—	—	—	—
All-Weather Package • Lineartronic® CVT • EyeSight® Driver Assist Technology ¹⁰ • Blind-Spot Detection with Lane Change Assist and Rear Cross-Traffic Alert ¹¹ • Power Rear Gate	—	○	—	—	—	—
SUBARU STARLINK™ 7.0-inch Multimedia Navigation • Harman Kardon® audio system	—	—	○	—	—	—
SUBARU STARLINK™ 7.0-inch Multimedia Navigation • Harman Kardon® audio system • EyeSight® Driver Assist Technology ¹⁰ • LED Steering Responsive Headlights with High Beam Assist • Reverse Automatic Braking ¹²	—	—	○	—	—	—

EQUIPMENT CONTENTS

EyeSight® Driver Assist Technology¹⁰: Pre-Collision Braking System, Pre-Collision Throttle Management, Lane Departure and Sway Warning, Lane Keep Assist, Adaptive Cruise Control

STARLINK™ Safety Plus and Security Plus¹⁵: Includes STARLINK™ Safety Plus services and adds Stolen Vehicle Recovery, Remote Lock/Unlock, Remote Horn & Lights, Remote Vehicle Locator and Vehicle Security Alarm Notification

All-Weather Package: Windshield wiper de-icer, heated side mirrors and heated front seats

Alloy Wheel Package: 17-inch alloy wheels, raised roof rails and front-passenger's auto-up/down power window

● Standard ○ Optional — Not equipped □ Available retailer-installed accessory

Forester | Accessories



Side Window Deflectors. Let the fresh air in while helping to keep the weather out. Black acrylic plastic construction is designed specifically for an exact fit.

May not be legal in all states. Please check your state laws.



Cargo Net. Neatly holds cargo and prevents it from sliding while the vehicle is in motion.



Door Edge Guards. Help protect your door edges from dings and dents with custom-fit, body-colored matched, stainless steel Door Edge Guards. They preserve the appearance of your Subaru while seamlessly blending into the door design.



All-Weather Floor Mats. Custom-fitted, heavy-gauge floor mats help protect the vehicle carpet from sand, dirt and moisture. Not intended for use on top of Carpeted Floor Mats.



Not Dimmed



Dimmed

Auto-Dimming Exterior Mirrors with Approach Light

Make it easier—and safer—to come and go with the accessory Auto-Dimming Exterior Mirrors with Approach Light.¹

When the doors are opened or unlocked with the key fob, LED lights on the side-view mirrors will help illuminate the way, casting light on all four doors and the ground near the vehicle.

They can also help reduce headlight glare in traffic. When the Auto-Dimming (Interior) Mirror detects excessive light from the rear of the vehicle, the side-view mirrors automatically dim, helping to keep the glare out of your eyes. The brighter the light, the dimmer the mirrors and the better you'll be able to see.

¹ Auto-Dimming Exterior Mirrors with Approach Light are accessory equipment. Requires Auto-Dimming Mirror.



Crossbar Set – Aero. Increase your vehicle's cargo-carrying capabilities by adding a crossbar set. These aero-style crossbars may be used in conjunction with Genuine Subaru roof attachments and carriers.



Cargo Tray. Tough, durable tray helps protect cargo area. Can be easily removed and rinsed clean.



Body Side Molding. Color-matched molding helps protect vehicle doors from parking lot dings while attractively blending with the lines of the car.



Luggage Compartment Cover. Keep items in the back out of sight with this fully retractable, maximum-coverage compartment cover.



Rear Seatback Protector. Provides additional protection to the rear seatbacks when lowering the seats to transport larger cargo. Use in conjunction with the Cargo Tray.



Rear Bumper Cover. Helps protect the upper surface of painted rear bumper from scratches and dings.



Trailer Hitch. Rated at 176 lbs tongue weight with 1,500 lbs of towing capacity. Engineered to the same rigorous standards as the rest of the Forester.
Hitch Ball not included. Trailer brakes may be needed.



Auto-Dimming Mirror with HomeLink.[®] This upgraded auto-dimming mirror detects glare and darkens automatically to protect your vision while featuring an 8-point digital compass. Three backlit HomeLink[®] buttons can be programmed to operate most garage doors, security gates, home lighting and more. Can also provide you with the last status of your garage door (open or closed) if programmed to a compatible opener featuring two-way communication.



Let nothing hold you back.

When your passion is even bigger than your cargo area, Genuine Subaru active lifestyle accessory attachments, manufactured by Thule[®], are a smart way to securely transport larger gear like bikes, skis, snowboards, kayaks, paddleboards and more. Each carrier safely attaches to your roof rack and can be removed if needed.



Thule[®] Ski and Snowboard Carrier

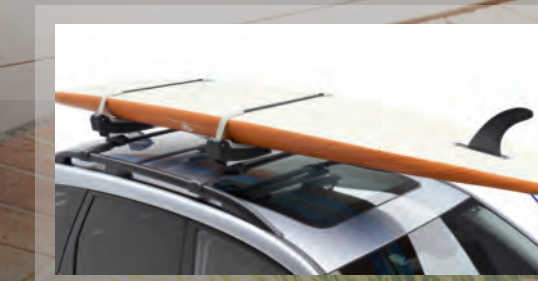

Thule[®] Paddleboard Carrier



Thule[®] Cargo Carrier

2018 Forester | Owner Benefits

For additional Subaru resources, including owner's manuals, maintenance schedules, roadside assistance and more, log on to www.mysubaru.com

Protecting Your Investment

Once you're part of our family, we'll be there for you. Every Subaru comes with 24-hour roadside assistance for 3 years or 36,000 miles. If you have trouble on the road, a tow to the nearest Subaru retailer and other services are just a phone call away. And to protect you over the long haul, we offer Added Security®...ask for it by name—extended service agreements and maintenance plans that will help protect your car for up to 7 years or 100,000 miles. They're the only mechanical and maintenance plans backed by Subaru, and because we've been backing them for more than 30 years, they're agreements you can trust. Your retailer has full coverage details.



Subaru Badge of Ownership

Subaru owners are driven by their passions. Whether hiking to see a sunset or skiing through fresh powder. Paddling through rapids or playing fetch with their furry friend. For many, our exclusive Badge of Ownership lets them personalize their vehicle and express their interests. Owners can go to badgeofownership.com to order FREE Subaru Badge of Ownership lifestyle icons.

Durability



Responsible. Reliable. Ready to join the family.

At Subaru, we're committed to building a lasting, rewarding relationship with you and the world we share. We start by building our vehicles to last—it's why 98% of all the Subaru Forester vehicles sold in the last 10 years are still on the road today.¹⁶ We also share your desire for a cleaner, greener world. In 2004, Subaru of Indiana Automotive, Inc. (SIA) became the first manufacturing facility in the U.S. to reach zero-landfill status—nothing from its manufacturing efforts ever goes into a landfill. Subaru is headquartered in a zero-landfill office in Cherry Hill, N.J.

Warranties

New Car Limited Warranty 3 years or 36,000 miles, whichever comes first.

Powertrain Limited Warranty 5 years or 60,000 miles, whichever comes first.

Wear Item Limited Warranty 3 years or 36,000 miles, whichever comes first. Repairs to the following items will also be covered under Wear Item Limited Warranty:

- Brake Pads
- Wiper Blades
- Clutch Linings
- Transmitter Batteries

Rust Perforation Limited Warranty 5 years, unlimited mileage.

24-hour Roadside Assistance 3 years or 36,000 miles, whichever comes first.

¹ Requires Lineartronic® CVT. ² 2.0XT Touring only. ³ 2018 EPA fuel economy estimates. Actual mileage may vary. ⁴ Available only with other features. See Optional Equipment listing. ⁵ The glass information listed represents calculated reference values and may not represent actual values determined by testing. ⁶ Standard with manual transmission. Optional with Lineartronic® CVT. ⁷ Compatible smartphone and applications required. For applications to operate, latest version of each application is required. Data provided by smartphone is displayed on the audio system screen. Some state laws prohibit the operation of handheld electronic devices while operating a vehicle. Smartphone apps should only be launched when vehicle is safely parked. Your wireless carrier's rates may apply. ⁸ Activation and required monthly subscription sold separately. Includes 4-month trial subscription. See your retailer. ⁹ Activation and monthly subscription sold separately. Includes 3-year trial subscription. ¹⁰ EyeSight is a driver assist technology, which may not operate optimally under all driving conditions. The driver is always responsible for safe and attentive driving. System effectiveness depends on many factors such as vehicle maintenance, weather and road conditions. The Pre-Collision Braking System is designed to provide automatic braking that either prevents a collision or reduces the severity of a frontal impact. The Pre-Collision Throttle Management System is designed to reduce acceleration and minimize the severity of certain frontal impacts. Adaptive Cruise Control and Brake Light Recognition are designed to assist the driver and are not substitutes for safe and attentive driving. Lane Departure and Sway Warning, and Lane Keep Assist operate only when the lane markings are visible and system effectiveness depends on many factors. See Owner's Manual for complete details on system operations and limitations. ¹¹ Blind-Spot Detection, Lane Change Assist and Rear Cross-Traffic Alert are systems designed to assist the driver by monitoring the rear and side areas of the vehicle during a lane change or reversing and are not a substitute for safe and attentive driving. ¹² This system is not a substitute for safe and attentive driving. System effectiveness depends on many factors, such as vehicle maintenance, weather and road conditions. Always exercise caution and use vehicle mirrors and the Rear-Vision Camera when backing up. See Owner's Manual for complete details on system operation and limitations. ¹³ Activation and required subscription sold separately. Includes 1-year trial subscription. See retailer for details. ¹⁴ The Supplemental Restraint System (SRS) (airbags) affords the driver and the front and rear outboard passengers additional protection in moderate to severe frontal and side-impact collisions. This system provides supplemental protection only, and seatbelts must be worn in order to avoid injuries to out-of-position occupants upon airbag deployment and to provide the best combined protection in a serious accident. Children should always be properly restrained in the rear seat. ¹⁵ Activation with subscription is required. See your retailer for details. ¹⁶ Based on IHS Markit U.S. vehicles in operation vs. new vehicle registrations in the Non-Luxury Compact CUV segment for MY2007–2016 as of February 2016.

2018 Forester | Dimensions

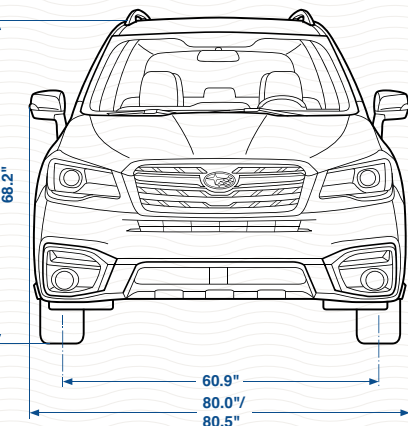
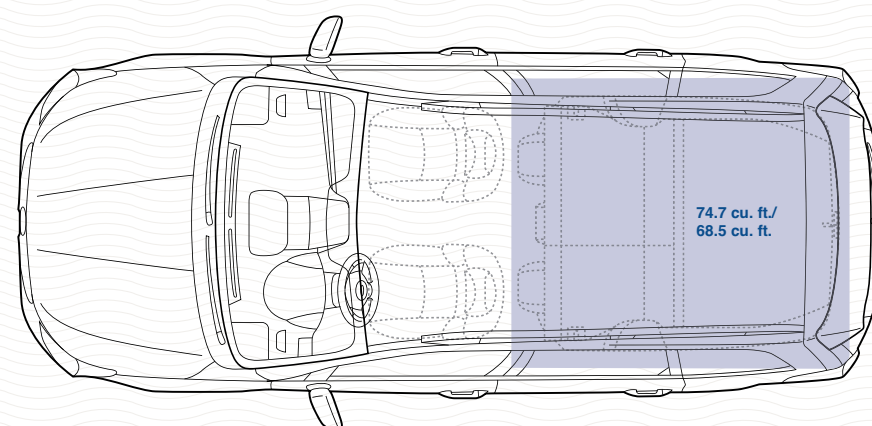
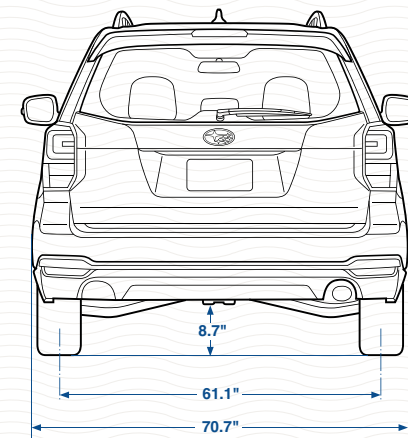
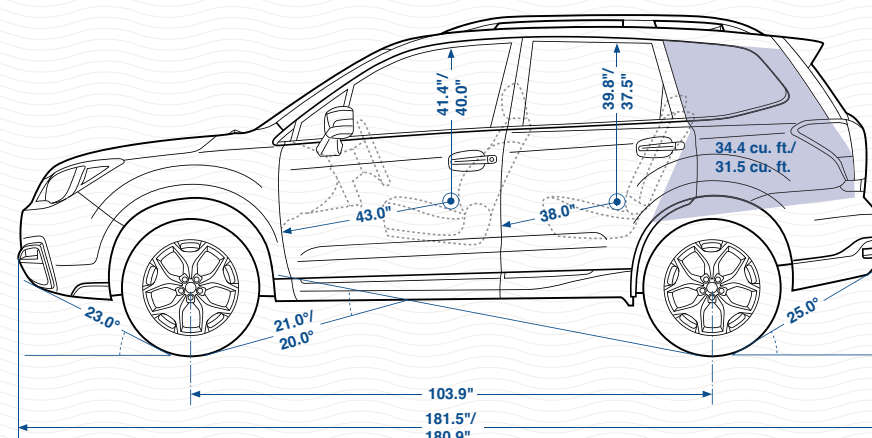

Length/Width/Height 181.5 inches (2.0XT: 180.9 inches)/70.7 inches (80.0 inches/80.5 inches¹ with side mirrors)/68.2 inches with roof rails (66.4 inches without roof rails)

Wheelbase 103.9 inches

Track (front/rear) 60.9 inches/61.1 inches

Base curb weight (manual/automatic) 2.5i: 3,322 lbs/3,395 lbs
2.5i Premium: 3,349 lbs/3,422 lbs
2.5i Limited: N/A/3,455 lbs
2.5i Touring: N/A/3,494 lbs
2.0XT Premium: N/A/3,653 lbs
2.0XT Touring: N/A/3,717 lbs

Ground clearance 8.7 inches (at base curb weight)

Headroom (front/rear) 40.0 inches/37.5 inches (without moonroof: 41.4 inches/39.8 inches)

Legroom (front/rear) 43.0 inches/38.0 inches

Shoulder room (front/rear) 57.0 inches/56.5 inches

Hip room (front/rear) 53.9 inches/53.0 inches

Passenger volume 103.3 cubic feet (without moonroof: 108.3 cubic feet)

Cargo volume 31.5 cubic feet (without moonroof: 34.4 cubic feet)

Maximum cargo volume 68.5 cubic feet with rear seat lowered (without moonroof: 74.7 cubic feet)

¹ With integrated turn signals.

Some images shown are for illustration purposes only. Specifications in this brochure are based on the latest product information available at the time of publication. For the most up-to-date and detailed product information, log on to www.subaru.com. Some equipment shown in photography in this brochure is optional at extra cost. Specific options may be available only in combination with other options. Specific combinations of equipment or features may vary from time to time and by geographic area. Certain accessories and equipment may not be available at the time of publication. Subaru of America, Inc., reserves the right to change or discontinue at any time, without notice, prices, colors, materials, equipment, accessories, specifications, models and packages without incurring any obligation to make the same or similar changes on vehicles previously sold. Colors shown may vary due to reproduction and printing processes.

This brochure was prepared by Subaru of America, Inc. A warranty from Subaru of America, Inc., is available only on cars sold to the first retail purchaser through an authorized Subaru retailer in the continental U.S. or Alaska. Every owner of the car during the warranty period shall be entitled to the benefit of these warranties. Subaru, SUBARU BOXER, Lineartronic, EyeSight and X-MODE are registered trademarks of SUBARU CORPORATION. Confidence in Motion and STARLINK are trademarks of SUBARU CORPORATION. Forester and Added Security are registered trademarks of Subaru of America, Inc. Harman Kardon® is a registered trademark of Harman International Industries, Inc. Aha™ is a trademark of Harman International Industries, Inc. Bluetooth® is a registered trademark of Bluetooth SIG, Inc. HD Radio® is a registered trademark of iBiquity Digital Corporation. HomeLink® and the HomeLink house icon are registered trademarks of Gentex Corporation. Apple®, App Store®, Siri®, iPod® and iTunes® are registered trademarks of Apple Inc. SiriusXM®, Traffic® and Travel Link® are registered trademarks of SiriusXM Radio, Inc. iHeart® Radio is a registered trademark of Clear Channel Communications, Inc. Pandora® is a registered trademark of Pandora Media, Inc. Stitcher™ is a trademark of Stitcher, Inc. Thule® is a registered trademark of the Thule Group. For more information, contact your Subaru retailer or log on to www.subaru.com.

2018 Forester | Colors

Paint

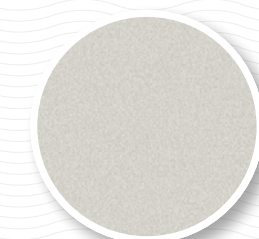

Crystal White Pearl

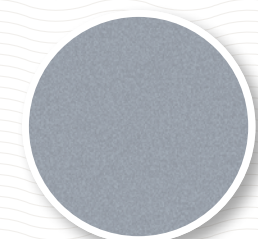

Ice Silver Metallic

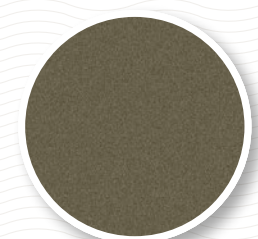

Sepia Bronze Metallic

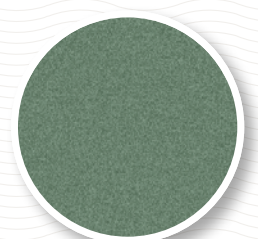

Jasmine Green Metallic

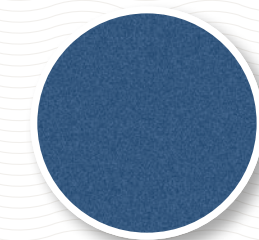

Quartz Blue Pearl

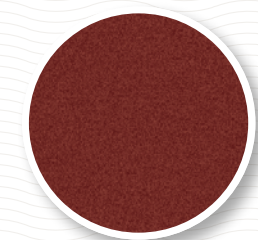

Venetian Red Pearl

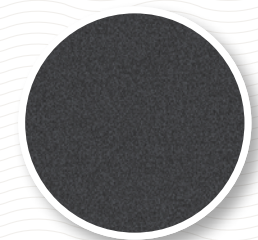

Dark Gray Metallic

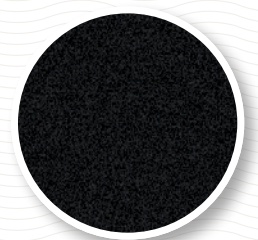

Crystal Black Silica

Upholstery



Black Cloth (BC)



Platinum Cloth (PC)



Black Cloth with Sport Bolsters (BCSB)



Black Leather (BL)

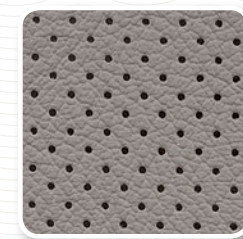

Platinum Leather (PL)

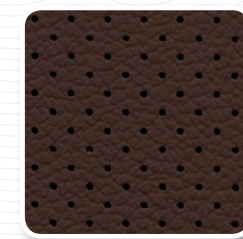

Saddle Brown Leather (SBL)

Color Combinations

	2.5i	2.5i Premium	2.5i Premium Black Edition	2.5i Limited	2.5i Touring	2.0XT Premium	2.0XT Touring
Crystal White Pearl	PC	PC	BCSB	PL	BL or SBL	BCSB	BL or SBL
Ice Silver Metallic	BC or PC	BC or PC	BCSB	BL or PL	BL	BCSB	BL
Sepia Bronze Metallic	—	—	—	—	BL or SBL	—	BL or SBL
Jasmine Green Metallic	PC	PC	—	PL	BL	—	—
Quartz Blue Pearl	PC	PC	—	PL	BL	BCSB	BL
Venetian Red Pearl	PC	PC	—	PL	BL	BCSB	BL
Dark Gray Metallic	PC	PC	BCSB	PL	BL or SBL	BCSB	BL or SBL
Crystal Black Silica	BC	BC	BCSB	BL	BL or SBL	BCSB	BL or SBL

— Not available

Take a Guided Tour

It's the ultimate way to get to know the Forester on your terms. Get up close and personal with color configurators, videos, 360-views, interactive content and so much more.



Online:

tour.subaru.com/forester2018



These brochures were printed with vegetable-based inks and produced using a "Green Printing Process." The Forest Stewardship Council® (FSC®) is an international organization that brings people together to find solutions which promote responsible stewardship of the world's forests and environments.

By producing these brochures in a green way rather than by traditional methods, we saved 67 trees preserved for the future; 31,163 gallons of wastewater flow saved; 2,086 lbs solid waste not generated; 5,745 lbs net greenhouse gases prevented; 30,000,000 BTUs energy not consumed. Calculations provided by Environmental Paper Network. FSC® is not responsible for any calculations on saving resources by choosing this paper.

This brochure is printed in Poland on 10% recycled paper. ©2017 Subaru of America, Inc. B-18FOR.SRB.525 (S-20333, 160K, 7/17, CG-PL)

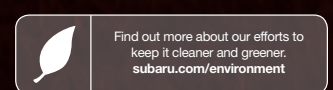

Love. It's what makes a Subaru, a Subaru.

